

CASE ERECTOR – PACKER - SEALER



Case Size	Min	Max
Length	6 ½"	20"
Width	3 ½"	14"
Depth	3 ½"	18"

Since 1962, Edson has been building case packing automation for users across 6 continents. As part of our success, the Edson 3200 Automatic Case Erector-Packer-Sealer has been satisfying customer demands with reliability, functionality, and speed. The 3200 is Edson's value based general purpose machine, which has the versatility to handle cartons to rolled products to bottles.

The standard 3200 provides users with the simplicity of pneumatic operation, a wide product range, with easy and quick changeover for side load or end load case packing applications.



Categories

Pharmaceuticals
Pet Food
Photographic & Copier Supplies
Detergent & Soap
Oil & Car Care
Cookies
Wines & Spirits
Candy & Confectionary
Cell Phones
Cereal

Snack Foods
Personal Care
Paint
Tiles & Flooring
Meat Chubs
Paper Towel
Video Cassettes
Cheese
Ice Cream
Nutraceuticals

Facial Tissue
Foil & Wraps
Wall Coverings
Home Care
Garden Care
Coffee
Pasta
Caulking Tubes
Toothbrushes

Light Bulbs
Auto Parts
Diapers
Frozen Entrees
DVDs / CDs
House Appliances
Paper Reams
Feminine Care
Hair Care

Feature	Function	Benefit
Mechanical Case Former	Mechanical forming devise is inserted into the KDF	Handles square cases and lower quality corrugate
All Pneumatic Actuation	Major motions are actuated by simple and maintainable 'off the shelf' pneumatic devices	Economical machine; standardized components
Low Mass Case Dispenser	Indexes cases through 4 packing stages, on a precision linear bearing case dispenser	Minimum air demand; faster case rates; better case control; off the shelf components
Large Vertical Case Magazine	110 – 130 KDF standard capacity in a horizontal attitude	Ergonomic loading; 10 – 30 min of production capacity
Design Flexibility	Wide Product & Case Size Range	Can handle a variety of pack patterns, product sizes and case sizes
Allen Bradley	Industry Standard PLCs	Maintainable; Upgradable; Easy to Program
Premium Acrylic Polyurethane Paint – 3 Standard Colour Choices	Smooth and resilient machine finish	Easy to wipe down; scratch resistant; matches other equipment

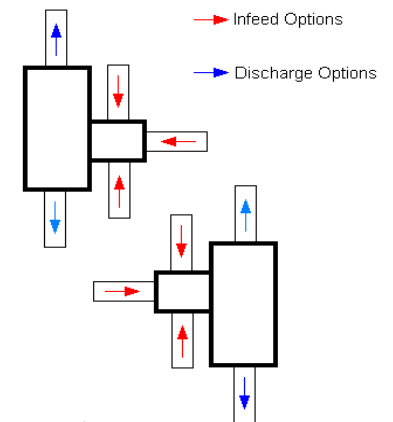
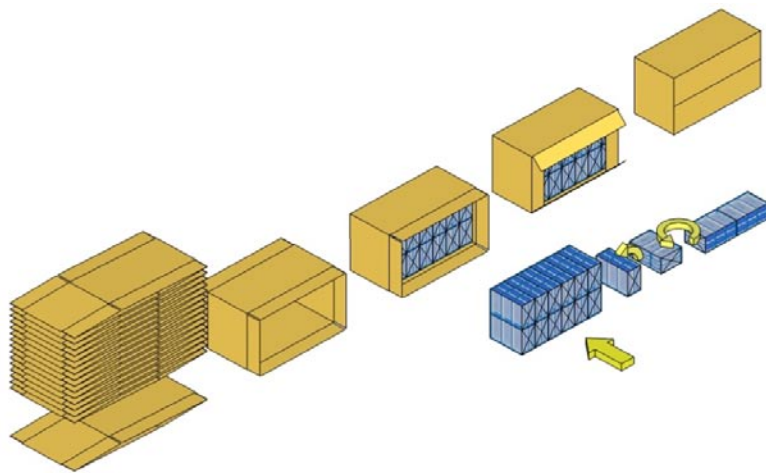

Available Machine Configurations

Design Simplicity for.... Maximum Capability

The **3200** is 4 station case packer with KDF dispensing, case erecting, case packing and case sealing. All motions are powered by long life pneumatic actuators. Sealing is a choice of either hot melt or PSA tape.

The **3200** can operate over a wide range of case packing rates, up to **22+ cpm**. Rate is affected by: pack patterns; product characteristics; case size & quality.