

CASE ERECTOR – PACKER - SEALER

Case Size	Min	Max
Length	12"	36"
Width	9"	24"
Depth	9"	36"



Since 1962, Edson has been building case packing automation for users across 6 continents. As part of our success, the *Edson 3100S Automatic Case Erector-Packer-Sealer* has been satisfying customer demands with reliability, functionality, and speed. The **3100S** is Edson's general purpose machine, that has the versatility to handle cartons to rolled product to bottles.

The standard **3100S** provides users with the simplicity of pneumatic & servo operation, a wide product range, with easy and quick changeover for side load or end load case packing applications.



Categories

Pharmaceuticals
Pet Food
Photographic & Copier Supplies
Detergent & Soap
Oil & Car Care
Cookies
Wines & Spirits
Candy & Confectionary
Cell Phones
Cereal

Snack Foods
Personal Care
Paint
Tiles & Flooring
Meat Chubs
Paper Towel
Video Cassettes
Cheese
Ice Cream
Nutriceuticals

Facial Tissue
Foil & Wraps
Wall Coverings
Home Care
Garden Care
Coffee
Pasta
Caulking Tubes
Toothbrushes

Light Bulbs
Auto Parts
Diapers
Frozen Entrees
DVDs / CDs
House Appliances
Paper Reams
Feminine Care
Hair Care

Feature	Function	Benefit
Mechanical Inside Case Former	Mechanical forming paddle is inserted into the KDF	Handles square cases and lower quality corrugate
Pneumatic/Servo Actuation	Major motions are actuated by simple and maintainable 'off the shelf' pneumatic/servo devices	Economical machine; standardized components
Low Mass servo Case Dispenser	Indexes cases through 4 packing stages, on a linear rail guided servo case dispenser	No air demand; faster case rates; better case control; off the shelf components
Large Vertical Case Magazine	130 – 150 KDF standard capacity in a horizontal attitude	Ergonomic loading; 10 – 30 minutes of production capacity
Design Flexibility	Wide Product & Case Size Range	Can handle a variety of pack patterns, product sizes and case sizes
Allen Bradley PLC	Industry Standard PLCs	Maintainable; upgradable; easy to program
Premium Acrylic Polyurethane Paint – 3 standard color choices	Smooth and resilient machine finish	Easy to wipe down; scratch resistant; matches other equipment

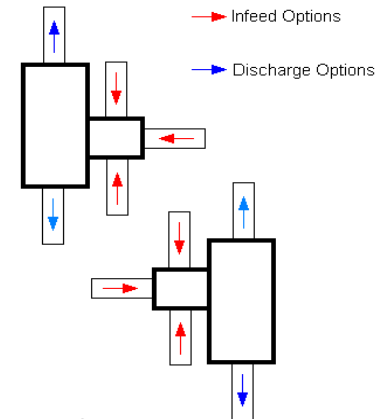
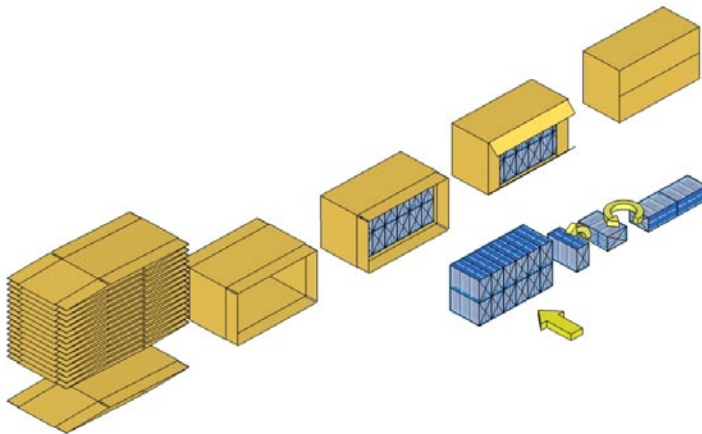

Available Machine Configurations

Design Simplicity for.... Maximum Capability

The **3100S** is a 4 station case packer: KDF load/dispense; case erect; case pack; flap tuck & seal. All motions are powered by long life pneumatic cylinders, and servo. Sealing is a choice of either hot melt or PSA tape.

The **3100S** can operate over a wide range of case packing rates, from **3 cpm to 22+ cpm**. Performance is affected by: pack patterns; product characteristics; case size & quality.